

LEDNINGSDIAGRAM - Trefaset version

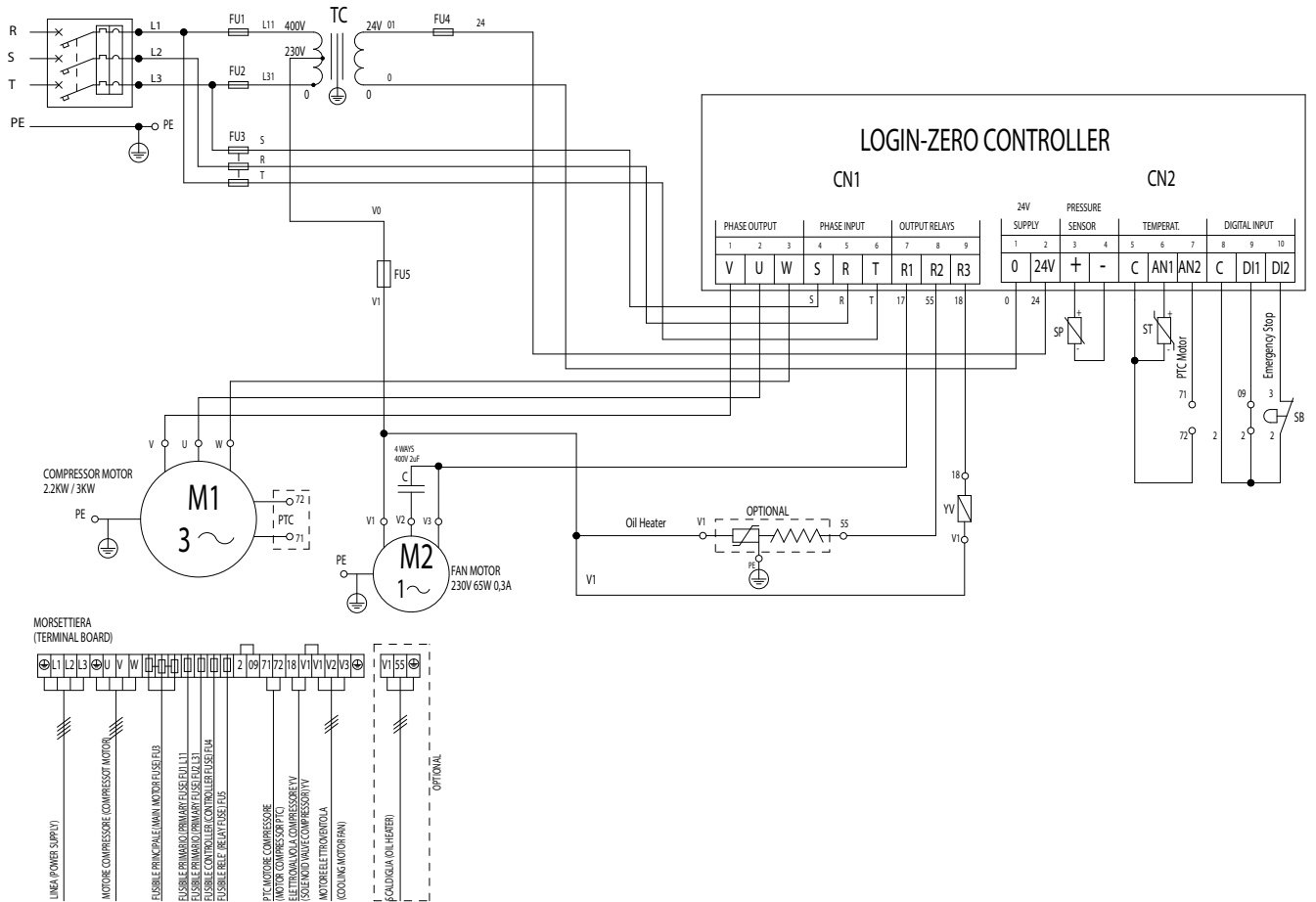

Ref.	Betegnelse - Denomination	2.2KW	3KW
TC	Transformer (TRANSFORMER) 80VA 400V-230V-0V Sek. 24V-0V		
ST	Termisk føler (TEMPERATURE PROBE)		
BP	Trykføler (PRESSURE SENSOR)		
SB	Nødstopknap (EMERGENCY BUTTON) + n.2 NC 230V 10A		
FU1-FU2	Porcelænssikringer (CERAMIC FUSES)	1A	1A
FU3	3x Porcelænssikringer 400V Motor (CERAMIC FUSE)	10A	12A
FU4	Sekundær sikring 24V (CERAMIC FUSE)	1A	1A
FU5	Porcelænssikring 230V relæ (CERAMIC FUSE)	2A	2A