

## PX20 1185X555

### SCALE PALLET TRUCK - SIMPLE WEIGHING SYSTEM



#### PX20

The PX20 pallet truck is the entry level model for lifting and weighing of transported loads, up to 2000 kg.

Thanks to the 4 load cells it is simple and functional in all internal weighing operations.

Ideal machine for checking incoming goods, avoiding overloads and determining shipping weights.



#### DISPLAY

Its 5 digits LCD display provides accurate and precise weighing in kg and lb.

Weights are shown in 1 kg steps with 0,1% precision.

Main functions are:

- Tare
- Unbalanced load
- Auto-off



## FRAME STRUCTURE

The structure is designed with a double frame consisting of a lower fork on which stands a counter fork. Both forks house two load cells allowing a uniform load distribution, and keeping high weighing accuracy even in case of collision and unbalanced load.



## BATTERY and BATTERY CHARGER

The PX20 is supplied complete with rechargeable battery and charger. The battery module provides 40 hours autonomy.



## CONFIGURATION PX20

**STANDARD:** nylon - polyurethane steering wheels and polyurethane tandem rollers



## Description

1.1 Manufacturer			PR INDUSTRIAL
1.3 Drive			Manual
Lift			Manual
1.4 Operator type			Pedestrian
1.5 Load capacity	Q	Kg	2000
1.6 Load centre distance	c	mm	600
1.8 Load axle to end forks	x	mm	975
1.9 Wheel base	y	mm	1250

## Weights

2.1 Service weight (battery included)		Kg	104
2.2 Axle load, laden rear		Kg	1476
2.2 Axle load, laden front		Kg	628
2.3 Axle load, unladen front		Kg	66
2.3 Axle load, unladen rear		Kg	38

## Tyres/Chassis

3.1 Tyres: front wheels			POLY.C
3.1 Tyres: rear wheels			POLY.I.
3.2 Tyre size: Steering wheels - Width		mm	55
3.2 Tyre size: Steering wheels - Diameter		mm	200
3.3 Tyre size: Load rollers - Diameter		mm	82
3.3 Tyre size: Load rollers - Width		mm	60
3.5 Tyre size: rear wheels - Q.ty (X=driven)		nr	4
3.5 Tyre size: front wheels - Q.ty (X=driven)		nr	2
3.6 Tread, front	b10	mm	155
3.7 Tread, rear	b11	mm	375

## Dimensions

4.4 Lift height	h3	mm	115
4.9 Height of tiller in drive position min	h14	mm	690
4.9 Height of tiller in drive position max	h14	mm	1160
4.15 Height, lowered	h13	mm	90
4.19 Overall length	l1	mm	1596
4.20 Length to face of forks	l2	mm	411
4.21 Overall width	b1	mm	555
4.22 Fork dimensions - Thickness	s	mm	60
4.22 Fork dimensions - Width	e	mm	180
4.22 Fork dimensions - Length	l	mm	1185
4.25 Distance between fork arms	b5	mm	555
4.32 Ground clearance, centre of wheelbase	m2	mm	30
4.34 Aisle width	Ast	mm	1851
4.35 Turning radius	Wa	mm	1426

**Performance data**

5.2 Lifting speed laden	strokes	13
5.2 Lifting speed unladen	strokes	13
5.3 Lowering speed laden	m/s	0.05
5.3 Lowering speed unladen	m/s	0.02

**Scale**

Digits	Q.ty	5
Digit height	mm	16
Kilograms		Yes
Lbs		Yes
Tare		Yes
Unbalanced load		Yes
Auto-off		Yes
Operating time	h	40
Accuracy	%	0.1
Shear-beam load cells	Q.ty	4
Division	Kg	1
6.4 Battery voltage	V	3.7
6.4 Battery capacity	Ah	2.4

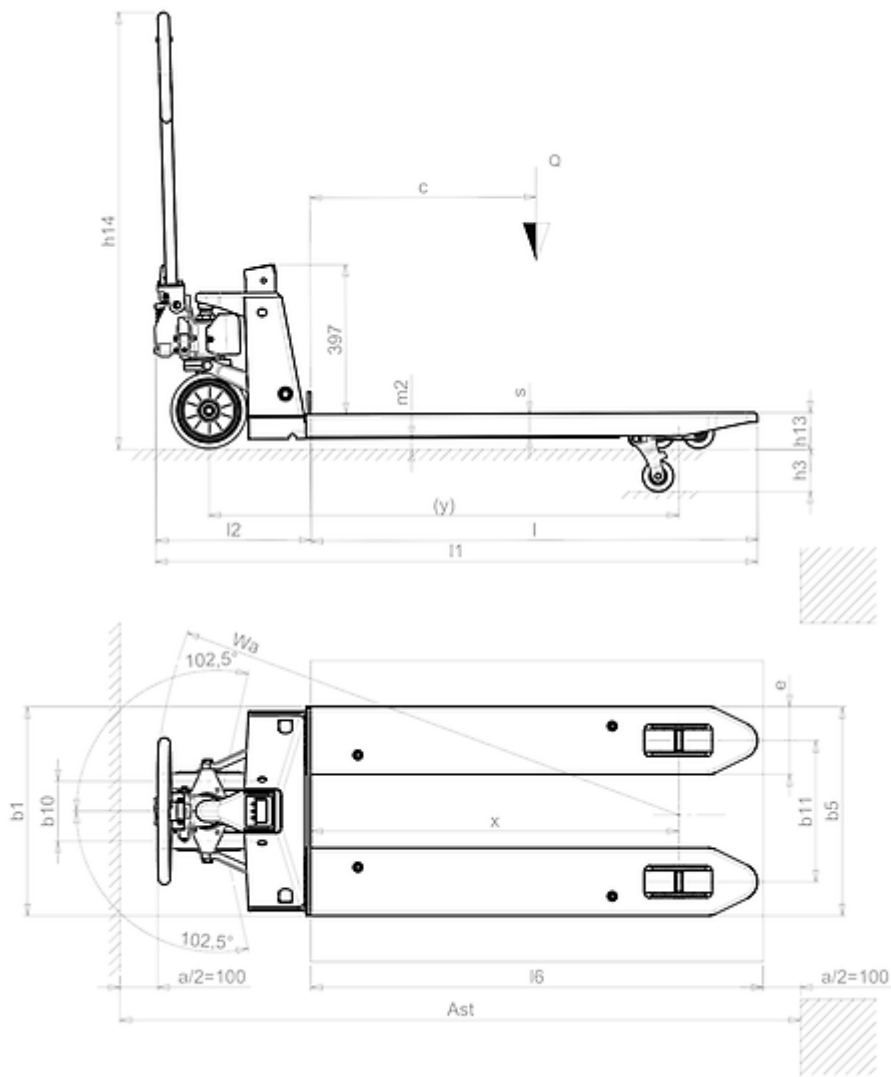

The information is aligned with the Data file at the time of download. Printed on 30/08/2021 (ID 12305)

©2021 | PR INDUSTRIAL s.r.l. | All rights reserved | Image shown may not reflect actual package. Specifications subject to change without notice

