

Spare Parts Catalogue

TX12-35

Stackers

Valid for machine code: HA712000000
Revision: 0 (04/2007)

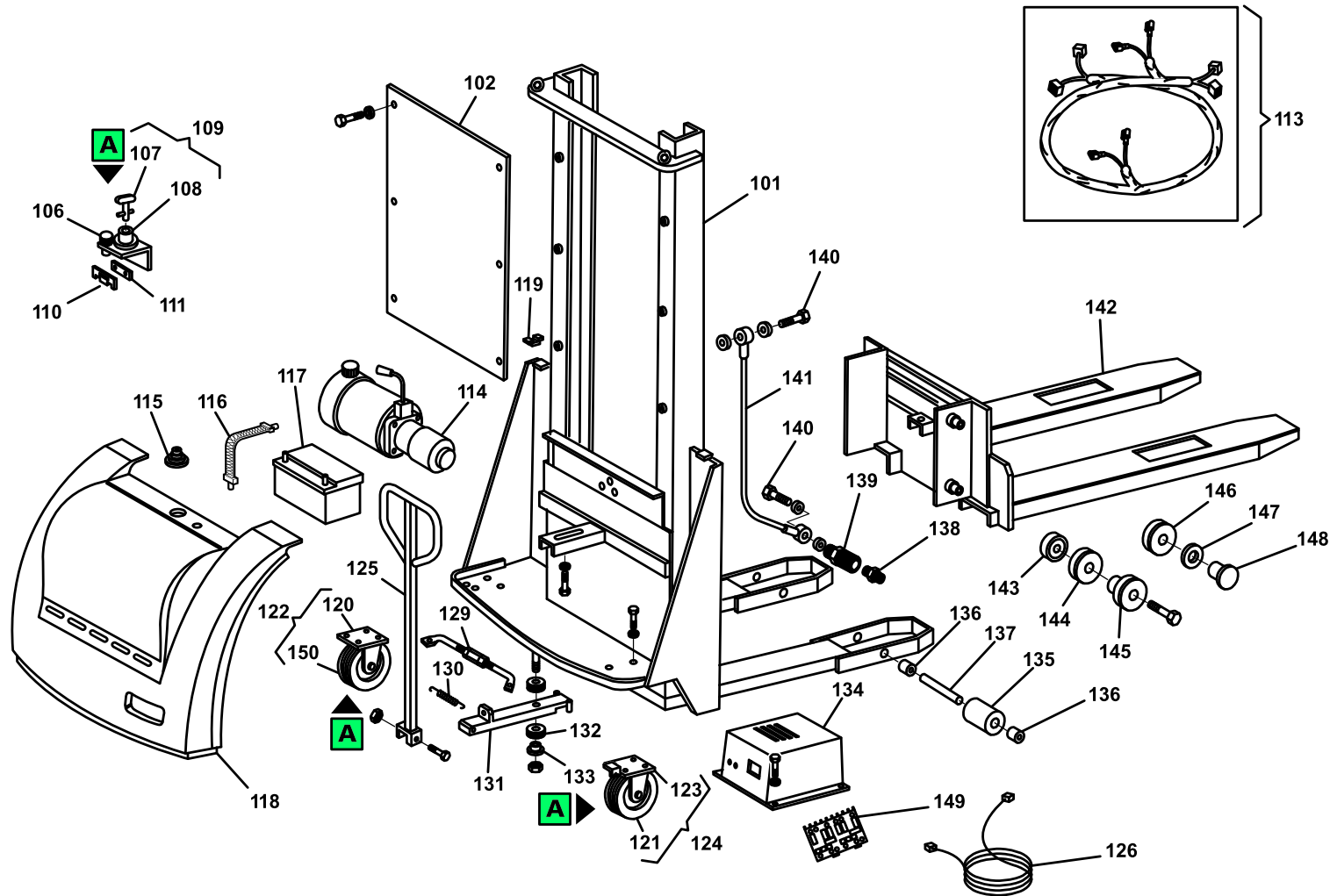

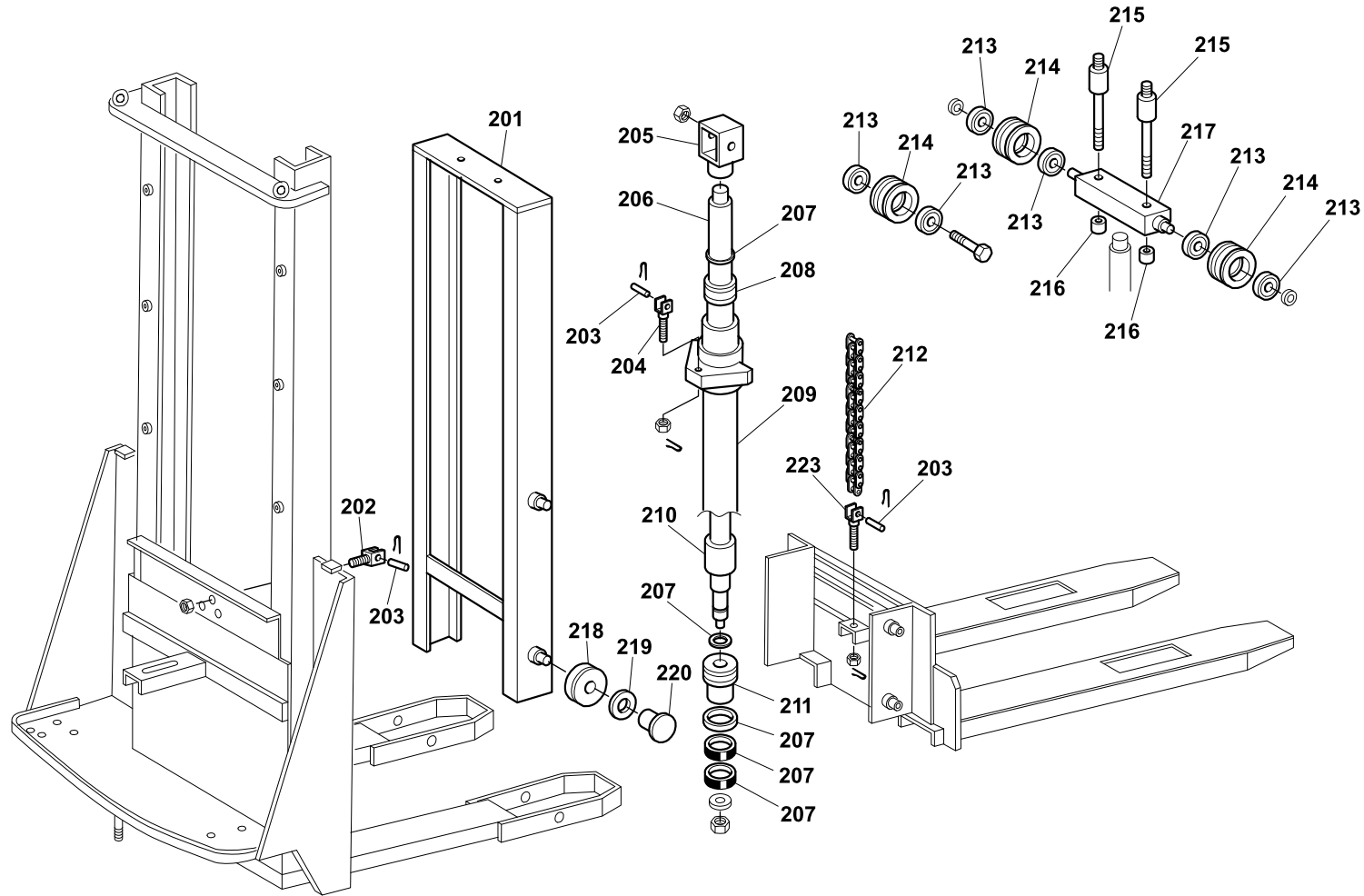

POSITION	PART NUMBER	DESCRIPTION	NOTES
101	V0201050098-PRAMAC	TELAIO TX 12/35 VERN.VERDE PRAMAC	
102	S0310018006	PLEXIGLASS GUARD TX10/20-16 TX12/29-35 GX12/29-35-38 GX10/16 FX12/29-35-38 G10 VERS.2	
106	G070625	FUSE HOLDER SCREW CAP + FUSE 6.3A	
107	G075220	KEY x BATTERY DISCONNECTING SWITCH	
109	G075102	BATTERY DISCONNECTING SWITCH 1 POLE	
110	G077540	FUSE 160A (RFM REGHEL)	
111	G070603	FUSE HOLDER x FUSE 160Amp	
113	▲ S0208020116	ELECTRIC WIRING CABLES TX	Attention: this item is valid for machines produced until 21/09/2003 Interchangeable: NO
113	▲ S000036001	ELECTRIC WIRE TX ELETTRICO TX	Attention: this item is valid for machines produced from 22/09/2003 Interchangeable: NO
114	▲ G081021	HYDRAULIC UNIT 222353003 UP100 (TX12- GX10-12)	Attention: this item is valid for machines produced until 21/09/2003 Interchangeable: YES
114	▲ G081029	CENTRAL S3010001.000 x TX12 - GX10/12	Attention: this item is valid for machines produced from 22/09/2003 until 02/10/2007 Interchangeable: YES
114	▲ G081035	HYDRAULIC UNIT TX12-GX10/12 '06	Attention: this item is valid for machines produced from 02/10/2007 Interchangeable: YES
115	G052002	RUBBER BELLOWS (FOR STACKERS)(0-RAB/010)	
116	G000111	BATTERY ELASTIC WEBBING TX12	
117	G099300024	STARTER BATTERY 12 V - 70 Ah C/20 DIM. MAX 275x175x190	
118	▲ S0200018012	HOOD GUARD TX 12	Attention: this item is valid for machines produced until 25/07/2011 Interchangeable: NO
118	▲ S000036903	BONNET COVER TX 12 '11	Attention: this item is valid for machines produced from 25/07/2011 Interchangeable: NO
119	G034903	CAGE NUT M8 ZN	
120	G053402	SWIVELLING HEAVY STAND FOR WHEEL D200x50	
121	S0014010233	POLYURETHANE WHEEL /ALL D200x50 LAG + BEARINGS 6204	
121	S0002010169	Rubber Wheel D200 (model No. Ea200bh-65a Lifter)+bearing	
123	G053401	SWIVELLING HEAVY STAND FOR WHEEL D200x50 + BRAKE	
124	G053102	RUBBER WHEEL D200x50 HEAVY SUPPORT + BRAKE	
124	G053305	POLYURETHANE WHEEL C D200x50 HEAVY SUPPORT WITH BRAKE	
125	S0204020113	HANDLE PAINTED TX 10-12	
126	PTB00019	CABLE 3x0.75 IECSK	
129	P0BR00002	HANDLE LINKAGE COMPLETE ARM TX12	
130	G001109	TRACTION SPRING P.49 HOOKS AT 90 DEGREES.	
131	S0202010080	HANDLE x TX 12 PAINTED	
132	S0202010031	HANDLE BEARING TM	

POSITION	PART NUMBER	DESCRIPTION	NOTES
133	S0204025010	LOWER LARGE WASHER TMC	
134	▲ G099300058	OPEN FRAME BATTERY CHARGER 13A-24V X TX12-GX10	Attention: this item is valid for machines produced with serial number until LLI0035913 Interchangeable: YES
134	▲ S000045930	HIGH FREQUENCY BATTERY CHARGER 12-24V 11,5A BRACKET GX/TX12 + CABLE IEC-SCHUKO 2m	Attention: this item is valid for machines produced with serial number from LLI0035913 Interchangeable: YES
135	S0202020029	NYLON ROLLER D82x70 + BEARINGS	
136	S0302016026	ROLLER SPACER SING.TX-GX (L.15) ZINC	
137	S0302015025	CLEVIS PIN TX/GX/LX "BURNISHED"	
138	G084103	MALE/MALE ADAPTATORS 3/8"	
139	G085003	FLOW CONTROL VALVE 3/8"	
140	G084001	SCREW PERFORATE (4 HOLES) 3/8" L 29 -0,5/0 CH22	
141	G083001	TUBE R1AT 3/8"	
142	S0307040063	COMPLETE FORK PAINTED TX/GX 12/35	
143	G010151	BEARING 6305 (25-62-17)	
144	S0207016006	SLIDING ROLL FORK TMC 10/16	
145	S0207018001	FORK ROLLER GUIDE GX/TX	
146	G019306	BEARING D70 (CSF.002)	
147	G019315	CONTRAST PLATE '01	
148	G019314 + G019315	DESCRIPTION N/A	
149	▲ PTB00014	RECTIFIER CARD HIGH FREQUENCY 24V 11.5A CBHD1 CX14	Attention: this item is valid for machines produced with serial number from LLI0035913 Interchangeable: NO
149	▲ PTB00001	ELCTRONIC BOARD FOR OPEN BATTERY CHARGER CX PLUS/CX/GX10/TX12/GX12	Attention: this item is valid for machines produced with serial number until LLI0035913 Interchangeable: NO
150	G053103	RUBBER WHEEL D200x50 HEAVY SUPPORT	
150	G053306	POLYURETHANE WHEEL C D200x50 HEAVY SUPPORT	

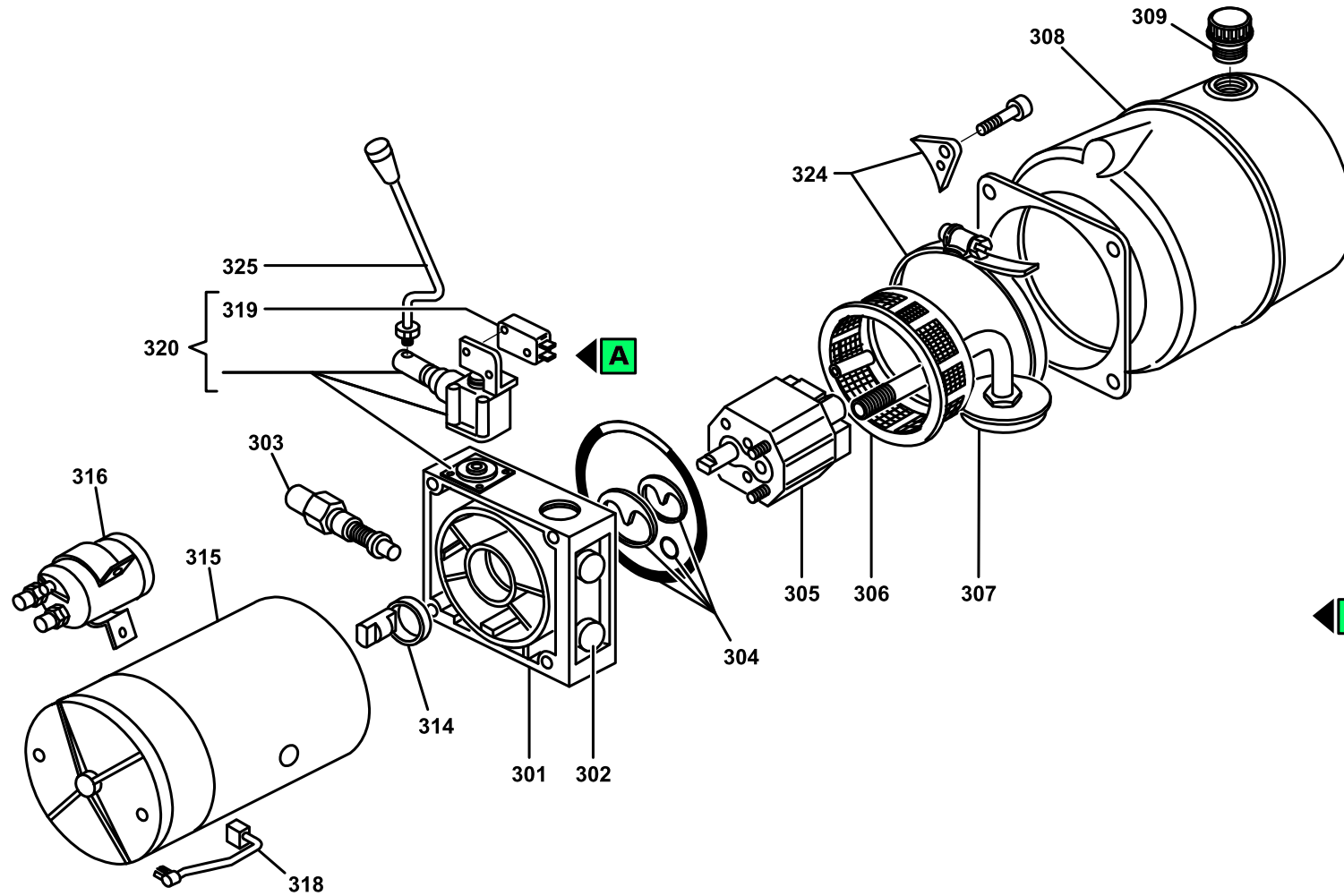

POSITION	PART NUMBER	DESCRIPTION	NOTES
201	V0305010286-9005	SECOND STAGE TX-GX 12/35 PAINTED	
202	S0307015015	SHORT CHAIN HOLDER TE-TM-L/VT ZINC PLATED	
203	G062104	FLAYER CHAIN PIN BL544 D6x29	
204	S0300185013	CHAIN HOLDER LX 12-14-16 ZINC PLATED	
205	S0306051022	CAST IRON PULLEY HOLDER TE-TM-L PAINTED	
206	S0306023054	CYLINDER SUPPORT STACKERS h3500 TX-GX 12/35	
207	▲ G090005	GASKET SET FX12/G10-16 20/GX12/L/LR/TE/TMC/TX12 OLD	Attention: this item is valid for machines produced until 19/07/2007 Interchangeable: NO
207	▲ GP90037	COMPLETE CYLINDER GASKET SET '06 FX-GX-TX12 NEW	Attention: this item is valid for machines produced from 19/07/2007 Interchangeable: NO
208	S0206011001	CYLINDER BUSHING TMC 10/16-20	
208	S0306041004	CYLINDER NUT RING TE/TM 10-12/29-36	
209	▲ S0306010287	CYLINDER TX-GX 12/35 PAINTED	Attention: this item is valid for machines produced until 19/07/2007 Interchangeable: YES
209	▲ S000045035	COMPLETE CYLINDER '06 FX-GX-TX12/35	Attention: this item is valid for machines produced from 19/07/2007 Interchangeable: YES
210	S0306026011	CYLINDER SUPPORT L.120 TE-TM	
211	S000045400	CYLINDER PISTON '06 FX-GX-TX12/35	
212	G062019	FLAYER CHAIN STUB BL534-131P	
213	▲ G010207	BEARING 6204 Z (20-47-14)	Attention: this item is valid for machines produced until 26/04/1999 Interchangeable: YES
213	▲ G010401	BEARING 6204 2RS (20-47-14)	Attention: this item is valid for machines produced from 27/04/1999 Interchangeable: YES
214	S0300158042	MACHINED PULLEY (CAST IRON) FOR STACKER 12Q SINGLE CHAIN	
215	S0306015052	FREE LIFT PIN L10-L16	
216	S0306015036	FREE LIFT PIN SPACER TE-TM	
217	S0306012072	DOUBLE PULLEY HOLDER L16 PAINTED "1998"	
218	G019306	BEARING D70 (CSF.002)	
219	G019315	CONTRAST PLATE '01	
220	G019314 + G019315	DESCRIPTION N/A	
221	S0306055043	CAST IRON PULLEY PIN HOLDER BURNISHED	
222	G010403	BEARING 6005 2RS (25-47-12)	



POSITION	PART NUMBER	DESCRIPTION	NOTES
301	G082195	BODY UP100 K1G3-06+OIL SEAL	
302	G082171	NON RETURN VALVE RS3/817-03	
303	G082107	RELIEF VALVE VM01 HDM10 T.95-210	
304	G082165	BODY GASKET SET UP100	
305	G082100	PUMP AP100/1.7 S.409+COP.748220020	
306	G082090	FILTER CONV.150 MICRON (757500070)	
307	G082196	GROUP A.H105L78-900 250M	
308	G082228	TANK UP100 P08,OR-BBT (673450200)	
309	G082099	LOADING CAP SF1/2G(HIDR.678000310)	
314	G082242	JOINT COMPLETEE145-E163	
315	G082230	ENGINE C240AK/Y0/D02P 024V 2.2	
316	G082127	COMPLETE RELAY 24V C.C. P.C-E-F-G (EF.)	
318	G082233	BRUSHES 24V	
319	G082223	MICROSWITCH FOR MANUAL COMMAND UP50-UP100	
320	G082224	VALVE ZR817/22-TVML + CAP	
324	G082227	TANK CLAMPING SET PL. UP100 6-14L.	
325	G082232 OUT OF PRODUCTION	DESCRIPTION N/A	
999	 G081021	HYDRAULIC UNIT 222353003 UP100 (TX12- GX10-12)	Attention: this item is valid for machines produced with serial number until 2003HG001450 Interchangeable: NO

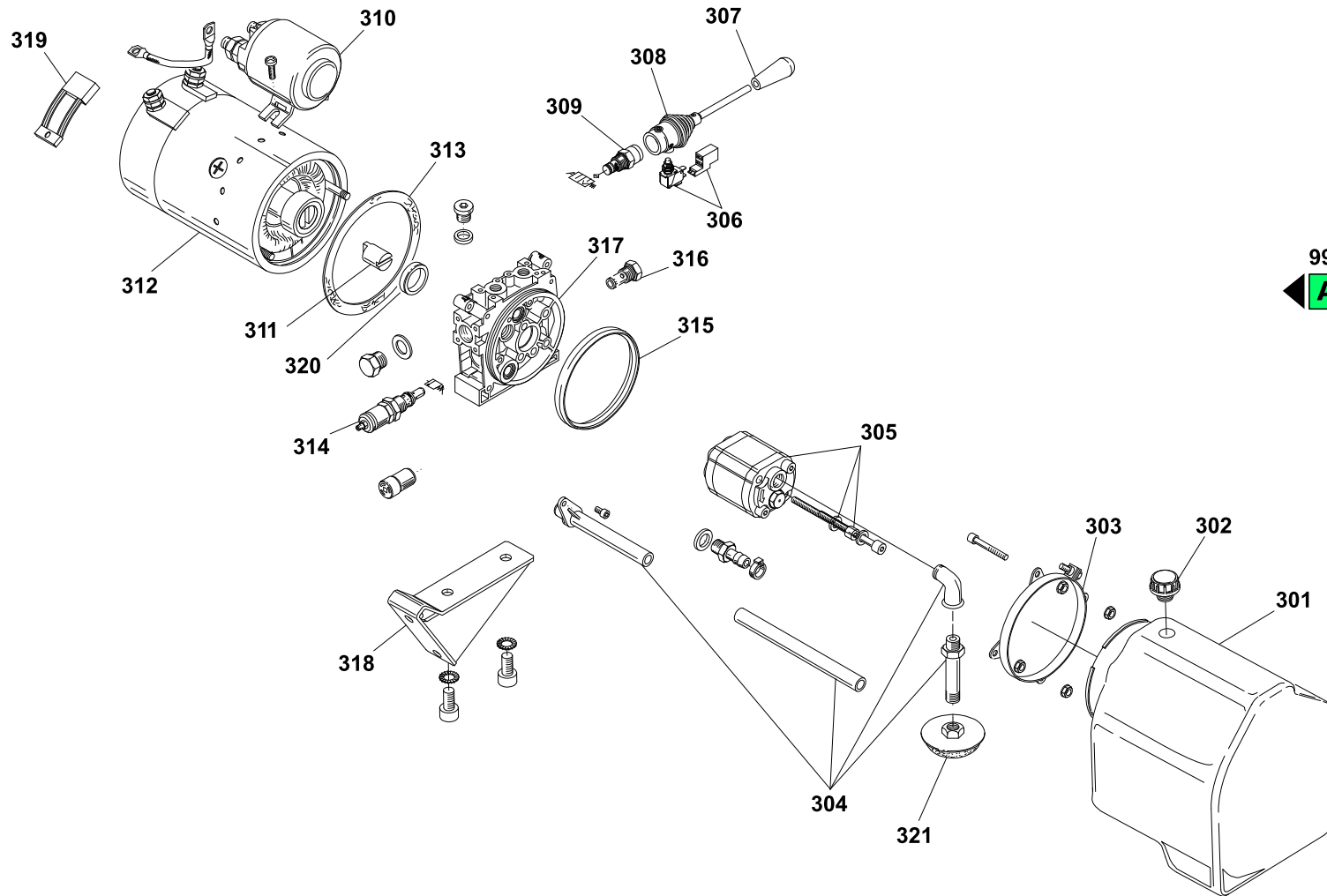

POSITION	PART NUMBER	DESCRIPTION	NOTES
301	PCY61214500	RESERVOIR BOTTLE	
302	PCY49154500	OIL CAP TANK TX HYDR-APP	
303	PCY25004800	BAND FOR HYDRAULIC UNIT H	
304	PCY12002	KIT TUBI TX HYDR-APP	
305	PCY00035	POMPA CENTRALINA	
306	PCY46109900	MICROSWITCH	
307	PCY49104600	POMELLO CENTRALINA HYDR-APP	
308	PCY25005800	HYDRAULIC POWER PACK COMPLETE LEVER	
309	PCY20023000	VALVOLA TX10/12	
310	G082127	COMPLETE RELAY 24V C.C. P.C-E-F-G (EF.)	
311	PCY60410600	GIUNTO A PENNA PER "MC" CON MOTORE ELETTRICO 2.05-2.2Kw E POMPE Gr.1	
312	▲ PCY24011800	ELECTR. MOTOR "FU" 24Vcc 2,2kW S-T - MFT	Attention: this item is valid for machines produced Interchangeable: YES
312	▲ PCY24011600	New code PCY24011800	Attention: this item is valid for machines produced Interchangeable: YES
313	PCY61200100	GASKET FOR HYDRAULIC UNIT H	
314	PCY21000001	VALVOLA MAX 50-210 BAR	
315	PCY61212400	HYDRAULIC UNIT O-RING HX	
316	PCY20020400	HYDRAULIC UNIT RETENTION VALVE HX	
317	PCY71013005	CENTRAL FLANGE	
318	PCY17010067	FIXING TX	
319	▲ PCY00004056	BRUSH KIT GX/10/12 TX12	Attention: this item is valid for machines produced Interchangeable: NO
319	▲ PCY00008001	BRUSH KIT	Attention: this item is valid for machines produced Interchangeable: NO
320	PCY60507900	SPACER FOR HYDRAULIC UNIT H	
321	PCY49122100	FILTER	
999	▲ G081029	CENTRAL S3010001.000 x TX12 - GX10/12	Attention: this item is valid for machines produced with serial number from 2003HG001451 Interchangeable: NO

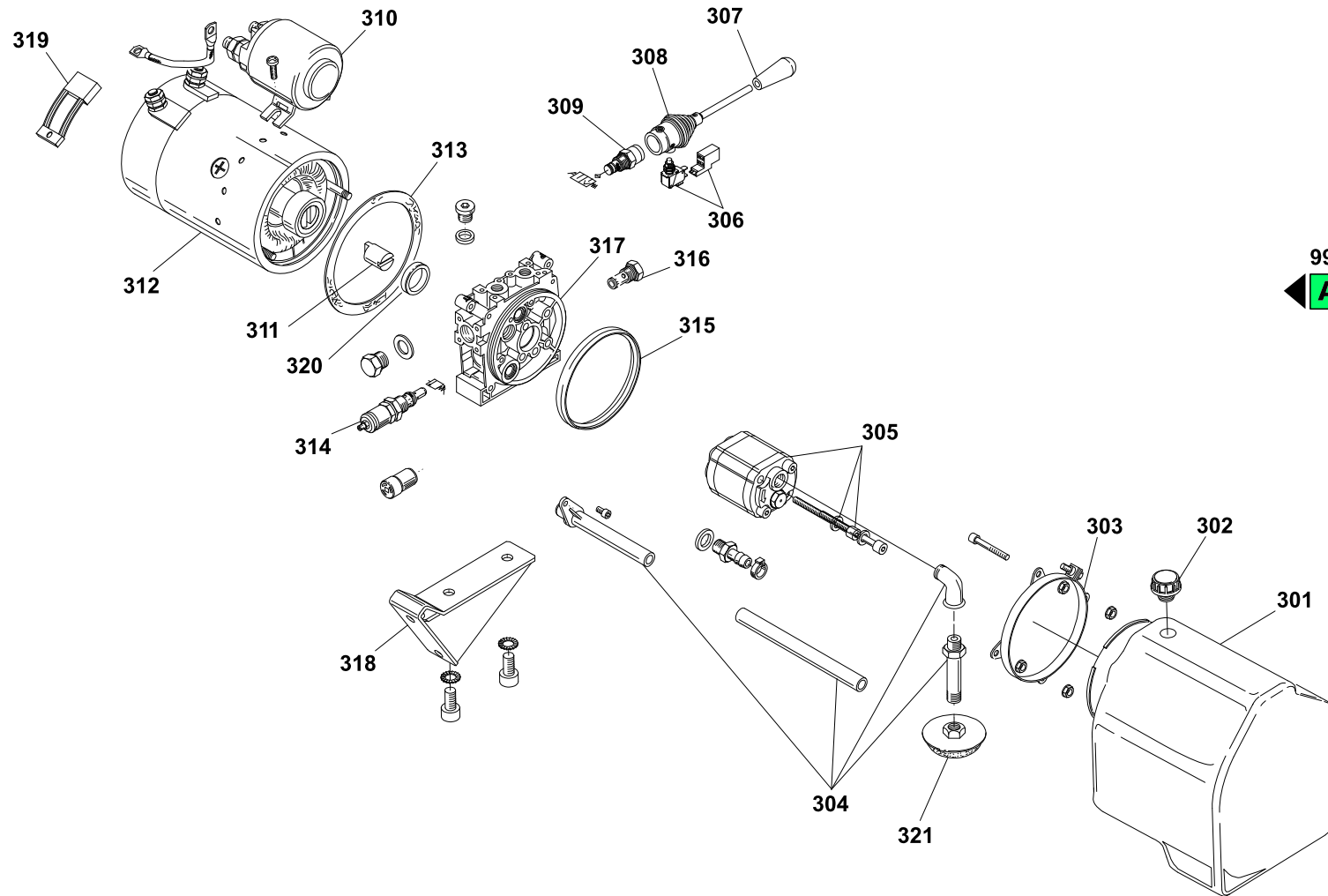

POSITION	PART NUMBER	DESCRIPTION	NOTES
301	PCY61214500	RESERVOIR BOTTLE	
302	PCY49154500	OIL CAP TANK TX HYDR-APP	
303	PCY25004800	BAND FOR HYDRAULIC UNIT H	
304	PCY12002	KIT TUBI TX HYDR-APP	
305	PCY00035	POMPA CENTRALINA	
306	PCY46109900	MICROSWITCH	
307	PCY49104600	POMELLO CENTRALINA HYDR-APP	
308	PCY25005800	HYDRAULIC POWER PACK COMPLETE LEVER	
309	PCY20023000	VALVOLA TX10/12	
310	G082127	COMPLETE RELAY 24V C.C. P.C-E-F-G (EF.)	
311	PCY60410600	GIUNTO A PENNA PER "MC" CON MOTORE ELETTRICO 2.05-2.2Kw E POMPE Gr.1	
312	▲ PCY24011600	New code PCY24011800	Attention: this item is valid for machines produced Interchangeable: YES
312	▲ PCY24011800	ELECTR. MOTOR "FU" 24Vcc 2,2kW S-T - MFT	Attention: this item is valid for machines produced Interchangeable: YES
313	PCY61200100	GASKET FOR HYDRAULIC UNIT H	
314	PCY21000001	VALVOLA MAX 50-210 BAR	
315	PCY61212400	HYDRAULIC UNIT O-RING HX	
316	PCY20020400	HYDRAULIC UNIT RETENTION VALVE HX	
317	PCY71013005	CENTRAL FLANGE	
318	PCY17010067	FIXING TX	
319	▲ PCY00004056	BRUSH KIT GX/10/12 TX12	Attention: this item is valid for machines produced Interchangeable: NO
319	▲ PCY00008001	BRUSH KIT	Attention: this item is valid for machines produced Interchangeable: NO
320	PCY60507900	SPACER FOR HYDRAULIC UNIT H	
321	PCY49122100	FILTER	
999	G081035	HYDRAULIC UNIT TX12-GX10/12 '06	