



This manual contains operating instructions and maintenance schedules for the high pressure breathing air compressors. Operators must read and understand all information inside the manual.

**ATTENTION.** This machine can be used only after a careful reading of this instruction manual. The machine may only be used to produce compressed air. Other use is strictly prohibited. The manufacturer and the supplier void all responsibility for damage or injury resulting from failure to follow these instructions.

### 1. GENERAL INFORMATION:

Before using the machine please put your attention to this general information:

1. Personnel engaged to operate the machine must have read the instruction manual before beginning work, especially the safety notices chapter.
2. Personnel may not wear long hair loose, loose clothing or jewellery, including rings.
3. Keep all safety and danger notices on the unit complete and in readable condition.
4. No modifications may be made to the unit which could impair safety without first obtaining permission from the suppliers.

5. Piping must be thoroughly checked (pressure and visual inspection) by the operator at appropriate time intervals, even if no safety related faults have been noticed..
6. Intervals stipulated or given in the instruction manual for recurring checks/inspections must be adhered to.
7. It is absolutely essential that the workplace is appropriately equipped for maintenance measures.
8. Work on/with the unit may only be carried out by reliable personnel. Observe the legal minimum age permissible.

### 2. PRESENTAZIONE GENERALE:

The ATLANTIC 100 high pressure compressors are designed to compress air for breathing as required in diving and fire fighting applications. The max pressure is 225 bar or 330 bar depending on unit.

The compressor unit comprises the following major assemblies:

Il compressore è composto da:

- . Compressor block
- . Electric or petrol/diesel engine
- . Filters

- . Filling assembly
- . Protection and anti-vibration frame
- . Automatic condensate drain\*
- . Electric control system\*\*
- . Automatic switch on/off\*
- . ALLUMINUM frame

(\*) Optional extra according to order

### 3. GRUPPO COMPRESSORE

The compressor block ATLANTIC 100 is used to compress air in the high pressure range up to 330 bar (4500 psi). The compressor block is of a four stage, four cylinders design. The cylinders are arranged in the 1st stage on the left, 2nd stage on the right, 3rd and 4th stage on the centre side looking from the filter side. The compressor blocks are particularly suitable for continuous operation because of their rugged design and the corrosion resistant intermediate filter and cooler assemblies. Smooth running is a particular feature of this Nardi design. The moving parts of the driving gear are all equally balanced. This results in a vibration-free running. The driving gear is fitted with energy saving cylinder roller bearings. The upper and lower connecting rod bearings are also roller bearings. Crankcase, cylinders and heads are obtained from the gravity dies. Connecting rod are extracted from casting dies. Cylinder are in cast iron inside an aluminium pipe.

**Description**

1. Intake Filter
2. 1st stage
3. Inter-cooler 1st stage
4. 2nd stage
5. Inter-cooler 2nd stage
6. 3rd stage
7. Inter-cooler 3rd stage
8. 4th stage
9. Inter-cooler 4th stage
10. Oil indicator

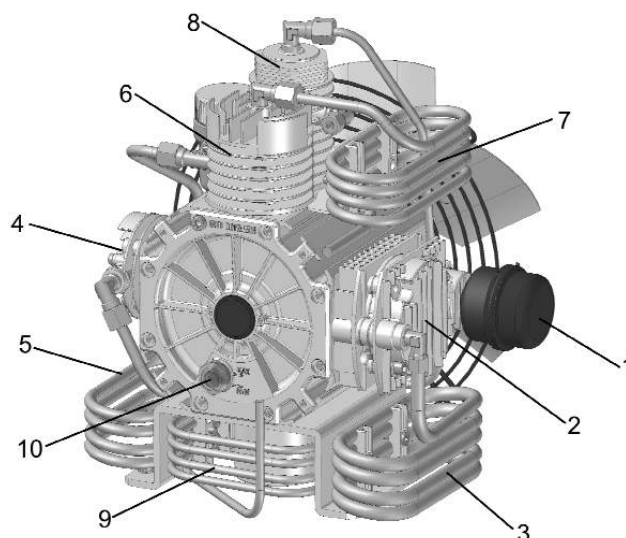
**4. TECHNICAL DATA**

Compressor unit	ATLANTIC 100	
Operating pressure	PN 200	PN300
Delivery *	100 L/min.	100 L/min.
Final pressure safety valve	225 Bar	330 Bar
Compressor block	ATLANTIC 100	
Number of stages	4	
Number of piston	4	
Cylinder bore stage 1	60 mm	
Cylinder bore stage 2	38 mm	
Cylinder bore stage 3	19 mm	
Cylinder bore stage 4	9,5 mm	
Piston stroke	23 mm	
Intermediate pressure stage 1	2,5 Bar	
Intermediate pressure stage 2	15 Bar	
Intermediate pressure stage 3	55 - 65 Bar	
Intermediate pressure stage 4	225 - 330 Bar	
Oil capacity	0,350 L.	
Oil Type	SHELL CORENA P150	
Max permissible ambient temp.	-5°C Min. +45°C Max. (+25°F Min. +113°F Max.)	
Max permissible inclination of compressor	20°	
Max dampness	80%	
Max sea level	2000 m sea level	
Weight	25 Kg.	
Drive engine	Mono phase	Three phase
Type engine	110-240 Volt / 50-60 Hz	230-400 Volt / 50-60 Hz
Power	3,0 Hp 2poli	
Speed	2850 r.p.m.	
Type of enclosure	IP 55	
Current rating	16,5 A (240 Volt) - ___ A (110 Volt)	
Petrol engine	ROBIN EX17 6,0 Hp 4 Stroke	
Switch on/off	MANUAL	
Cubic capacity	169 ml.	
Power	2,9 Kw-4,00 HP / 3600 r.p.m.	

**5. SAFETY MEASURES**
**5.1. Fundamental safety notices:**

Important instructions concerning the endangerment of personnel, technical safety and operating safety will be specially emphasized by special marks placing on the machine.

For safety reasons you can find some components mounted on the compressors in order to prevent damages. These parts must not be changed or removed in any case. Before please consult our technician.

**5.2. Authorized use :**

The unit is built according to state of the art technology and established safety technical regulations. Nevertheless, its use can cause danger to life and limb of the operator or third parties or damage to the machine and other equipment. Operate the unit only in technically perfect condition in accordance with regulations and safety danger notices detailed in the instruction manual. The manufacturer/supplier is not responsible for damage resulting from a wrong utilisation of the machine. The user alone is responsible for this risk. The compressor is built to produce top quality breathing air according to DIN EN 12021 rules.

**5.3. Safety notices for operation :**

- Ensure that only trained personnel work with the machine.
- Filling hoses must be in satisfactory condition and threads undamaged.
- Ensure intake air is free from noxious gas, exhaust fumes and solvent vapour.
- The use of petrol and diesel compressors is forbidden in indoor place.
- Check the unit externally for damage and faults periodically. Inform the department/person responsible immediately if anything is not as it should be (including operation). If necessary, shut the machine down immediately and make it safe. Observe switching on and off processes and monitoring indications according to the instructions manual.
- Use only Nardi original parts and equipments.
- Drain the valve regularly if manual drain valve. Check every **ten minutes** the valve if automatic drain valve.
- Switch off the machine when do not use it.
- Clean oil, fuel or care products from, the machine, in particular the connections and screw joints, before carrying out maintenance/repair work. Do not use aggressive cleaning fluid. Use a fibre-free cleaning cloth.
- Completely remove all covers/seals after cleaning.
- Use only original fuses with specified current rating. If there is a failure in the electric energy supply, shut the machine/unit down immediately.
- Work on electric units or operating equipment may only carried out by a qualified electrician or by a person under the instruction and supervision of qualified electrician according to electric technical regulations.
- The electrical equipment of a unit must be regularly checked.
- When working in small rooms, observe any national regulations.
- Depressurize system and pressure lines before commencing repair work.
- With regard to oil, grease and other chemical substances, observe the relevant safety rules for the product.
- When switching on the machine, check the arrow to ensure correct direction of rotation of the drive motor.

**5.4. Electrical installation:**

For installation of electrical equipment observe the following:

In the annex of this instruction manual you will find the standard schematic diagrams valid for the respective compressor unit.

Observe regulations of local electricity supply company.

Connection must be carried out by an expert only.

Ensure correct installation of protective conductor.

Check conformity of motor and control device tension and frequency with those of electric network.

**ATTENTION:** check the correct direction of the fan.

**6. OPERAZIONI PER L'AVVIAMENTO:****6.1 Preparation for operation.**

**WARNING:** this machine is built to produce breathing air. It is not suitable for compression of oxygen. Explosion occurs if an oil lubricated compressor is operated with pure oxygen or gases with oxygen content of more than 21%!

All compressor units are tested prior to delivery to the customer, so after correct installation of the unit there should be no problem putting it into operation, observing the following points:

Prior to first operation read Instruction Manual carefully. Make sure that all persons handling the compressor and the filling station are familiar with the function of all controls and monitors.

Immediately after switching on the system for the first time check the direction of rotation of the motor for compliance with the arrow on the unit. If motor turns in the wrong direction, the phases are not connected properly. Shut down unit immediately and interchange two of the three phase leads in the switch box. Never change leads at the motor terminal board.

Prior to each operation check the oil level. Only for petrol unit: - check engine oil level according to manufacturer's instruction manual - check fuel tank. Top up if necessary - open fuel shut-off valve.

Every time the unit is started up check all systems for proper operation. If any malfunction is observed stop unit immediately and find the cause of the fault or call the service department.

**6.2. Starting the unit:****Unit with electric engine without compressor control system:**

The motor is switched on manually by pressing the start button. Machine does not be left alone during working. Check continuously the right function.

On units without automatic condensate drain, the manual condensate drain valves have to be opened before starting the unit, as soon as the unit is running the valves can be closed again. Every 8/10 min drain the valves.

**Units with electric engine with automatic control system:**

This model is delivered with an automatic control system.

Before starting check point 6.1 and then press ON button. Switch off the machine pressing STOP button.

**Units with petrol engine:**

Open condensate drain valves on the filters to release pressure, so that motor start without load. Set choke to position START. Start engine with recoil starter or crank handle. As soon as motor runs smoothly return choke to normal operating position.

For all units:

Close condensate drain valves tightly and run unit to final pressure. Check final pressure safety valve and pressure gauge. As soon as final pressure is reached and final pressure safety valve blows off, open condensate drain valves and drain condensate - unit is ready for filling operation.

**7. FILLING PROCEDURE:****7.1. Connecting the bottles:**

**WARNING:** Filling hoses must be in satisfactory condition and threads undamaged. Pay particular attention to damage on the interface from hose fitting to hose. If the rubber is scored, hose must be discarded otherwise water can enter and attack wire gauze causing it to rust.

Normally connectors are allowed for pressures up to 200bar (2.850psi).

Please follow the process below:

- Connect air bottle to filling valve.
- Open filling valve.
- Open bottle valve-bottle will be filled. .
- Switch on the compressor.
- Upon reaching final bottle pressure close bottle valve first, then filling valve by returning handle to closed position.
- Remove compressed air bottle.
- Depressurize unit before opening valve-A to avoid damage to the change - over device.

**If it is necessary more pressure of 220bar please ask for the suitable material: safety valves and connectors are different.**

**8. MAINTENANCE :****8.1. Maintenance record:**

We recommend that all maintenance work is recorded in a service book, showing the date and details of the work carried out. This will help to avoid expensive repairwork caused by missed maintenance work.

Please fill in the appropriate lines to show what maintenance work has been carried out, and sign and date.

Remember:

- 1- always shut down and decompress the complete system prior to carrying out any work on the compressor;
- 2- never repair pressure lines by soldering or welding;
- 3- only use original spares for maintenance or repair work.

**8.2. Maintenance schedule:**

<i>After first 25 operating hours</i>	<i>Date</i>	<i>Signature</i>
Clean intake filter and intake filter cartridge		
Check Oil level ( Max. RED POINT )		
Cartuccia Filtro Carboni – setaccio		
Check tightness of all cooler-pipes and couplings		
Check tightness of O-rings		
Check functioning and tightness of filling valve		
Check zero position on final pressure gauge when depressurized		

<i>After first 50 operating hours, at least annually</i>	<i>Date</i>	<i>Signature</i>
Oil change 350 ml.		
Check and clean intake filter element 1st stage		
Check filter and cartridge		

<i>After first 500 operating hours, at least annually</i>	<i>Date</i>	<i>Signature</i>
Valve change		
Change intake filter element 1st stage		
Check blow-off pressure of final pressure safety valve		

<i>After repair work</i>	<i>Date</i>	<i>Signature</i>
Check functioning and tightness of filling valve		
Clean intake filter element 1st stage		
Check tightness of O-rings		
Check zero position on final pressure gauge when depressurized		

## 9. MAINTENANCE WORK

This chapter contains the maintenance work as well as short functional description for each component.

### **9.1. Lubrication :**

The lubrication system is a **Splashed lubrication**. Mechanic lubrication by connecting-rod movement. Connecting-rod has a metal piece below that splashing in the oil during the fast movement causes a spray inside the cylinder.

### **9.2. Type of oil :**

Using the correct oil is of vital importance for life and maintenance of the compressor. Nardi has a particular oil studied and tested for the best operation of his machine. Depending on the application of the compressor the requirements placed on the oil are:

- low deposits
- No carbonizing effect, especially in the valves
- Good anti-corrosive properties
- For breathing air application, also physiological and toxicological suitability.

Due to the thermal load on the compressor only high quality oil should be used. You are recommended to restrict oils to those which have been approved by us: oil for not mixed air (21% O<sub>2</sub>).

### **9.3. Oil change :**

Please follow the procedure as below:

- Ensure to have a sufficient quantity of oil.
- Run compressor warm.
- Remove red cap from oil filler neck and drain oil while still warm by means of oil drain plug.
- Remove oil filter.
- Mount a new filter element.
- Fill new oil though filler neck to Max.—mark at sight gauge.

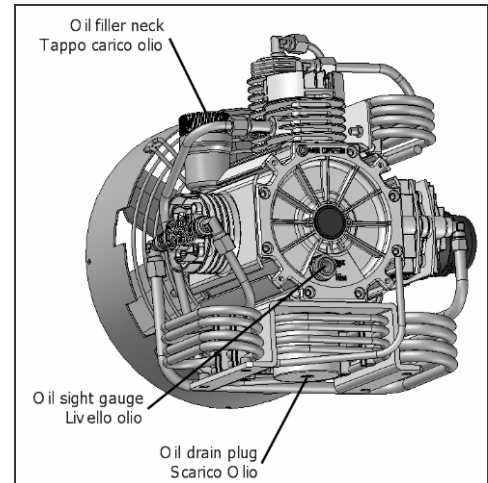

### **9.4. Changing the oil type:**

To avoid severe damage to the compressor unit when changing the oil type, the following measures should be strictly adhered to:

- Follow the procedure Chapter 9.3.
- Change or clean all parts with old oil.
- After approx. 10 operating hours check lubricating oil for degree of contamination, and change oil again if necessary.
- Fill compressor with the new oil and do not mix different oils.
- Refill compressor with same oil, only.

### **9.6. Intake filter**

A dry micronic filter is used to filter intake air. The filter cartridge must be cleaned or changed at regular intervals according to maintenance schedule. Do not use any cleaning fluids which are a hazard to respiration.

Please clean intake filter as following:

- Remove micronic filter cartridge.
- Clean with brush or by blowing air inside out.
- Change with a new filter and make sure that top cover is installed properly.

### **9.7. Intermediate separator**

Separators are designed to remove water and oil accumulation due to cooling the air down after the compression process. An intermediate separator is mounted on the compressor between stages.

Clean filter element as follows:

- Switch off the compressor and depressurize separators.
- Remove piping connected to filter head. Screw off union nut. Remove filter head.
- Clean filter element using hot soapy water and blow dry with compressed air.
- Replace O-ring.
- Close the filter strongly.

**9.8. Coal filter cartridge :**

Coal filter cartridge removes water condensation and oil by a chemical system not mechanical. Activated carbon and molecular sieve absorb water and oil purifying breathing air according to DIN EN12021.

The filter system is subject to dynamic load. It is designed for a certain number of load cycles, which originate from an abrupt pressure loss at condensate drain. After 500 operating hours an inspections have to be arranged by the operator. After reaching the max. number of load cycles: 8000 cycles at 300Bar or 21000cycles at 225Bar the filter assembly must be replaced. Approximately, with 4cycles per hour at 300 bar filter must be changed after 2000 operating hours instead at 225 Bar after 5000 operating hours..

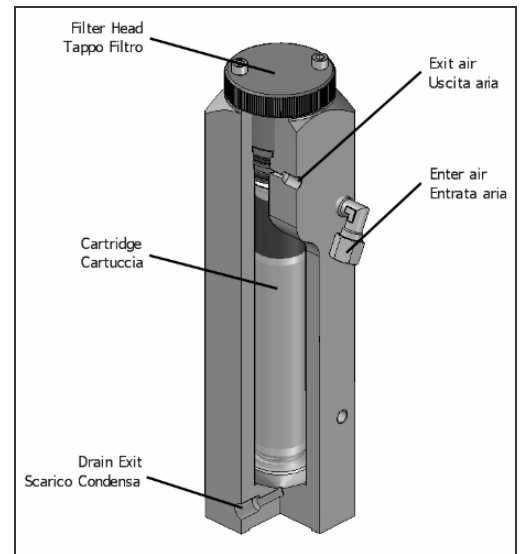

**9.9. Filter maintenance :**

The cartridge in the picture removes water and oil

Please follow the procedure below:

- Depressurize system before starting any maintenance work.
- Dry inside of filter housing with a clean cloth before installing new cartridge and check for corrosion. Change if necessary.
- Check the O-ring and change it if damaged.
- Change cartridge before reactivating a compressor unit.

The number of operating hours or the amount of possible bottle fillings per filter cartridge can be determined taking into consideration the ambient temperature and the cartridge used.

To avoid any danger to your health or damage to your unit, change used up cartridges in good time. Never fill used up cartridges yourself. The filter material was chosen specifically by Nardi compressori for each kind of application. Never remove replacement cartridge from packaging prior to actual use otherwise highly sensitive molecular sieve will absorb water vapour from surrounding air and cartridge saturated.

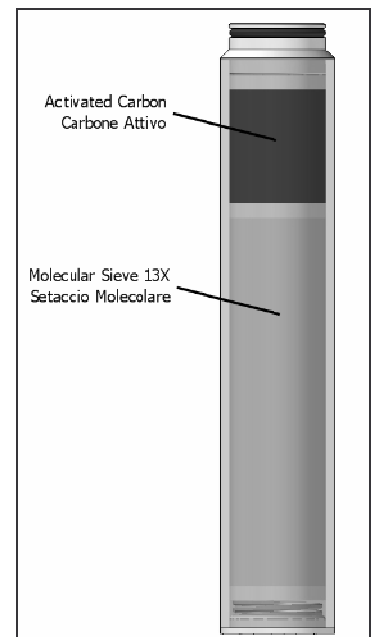

**9.10. Lifetime of filter cartridge :**

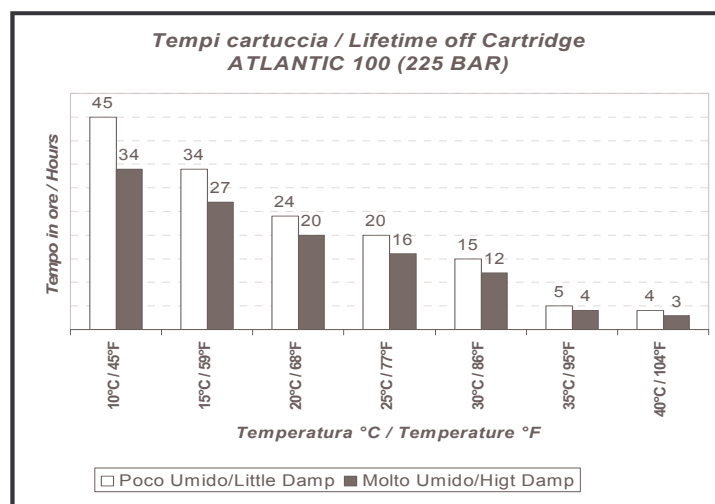

### **9.11. Valves:**

The valve heads of the individual stages form the top part of the cylinders. The intake and pressure valves are fitted inside the valve heads. Note that the valves are operated by the flow of the medium. On the suction stroke, the intake valves open and the medium flows into the cylinders. At the start of the compression stroke the intake valve closes and the medium opens the pressure valve.

Please follow the instructions below for changing the valves:

Always replace valves as a complete set.  
Carefully clean dirty valves.

### **9.12. Valve change:**

#### **Changing the valve of the 1st stage:**

Put the attention at the picture and check that the mark 'T' is really at the top. Remove gaskets and O-rings if damaged.

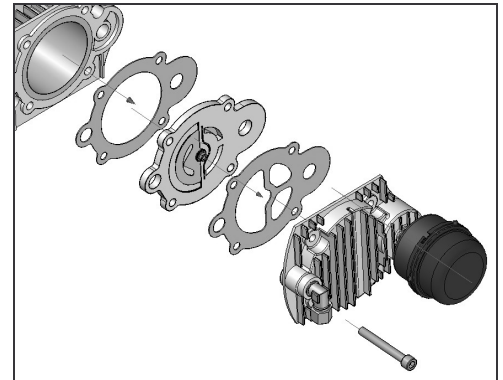

#### **Changing the valve of the 2nd stage:**

Please follow the procedure below:

- Unscrew the intake and pressure lines from the cylinder head.
- Unscrew the screw of valve-cover.
- Clean intake and pressure valves and check for wear. Valve seats and plate valves must not show any signs of wear or damage. Replace damaged parts.
- Assembly is performed in the reverse sequence of removal.
- Check the pressure valve function and stroke by lifting the valve plate.
- Check O-rings and replace them if damaged.
- Fix the valve-cover.

Reconnect the intake and pressure lines.

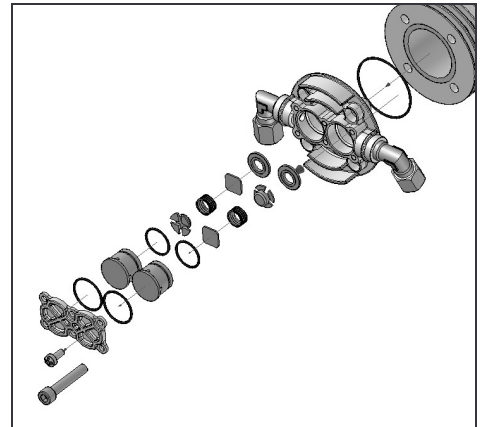

#### **Changing the valve of the 3rd – 4th stage:**

Please follow the procedure below:

- Unscrew the intake and pressure lines from the cylinder head..
- Fix the head
- Unscrew the intake valve body.
- Clean intake and pressure valves and check for wear. Valve seats and plate valves must not show any signs of wear or damage. Replace damaged parts.
- Assembly is performed in the reverse sequence of removal.
- Peen the cylinder head on the screw.
- Check the pressure valve function and stroke by lifting the valve plate.
- Check O-rings and replace them if damaged.
- Fix the head at cylinder.
- Reconnect the intake and pressure lines.

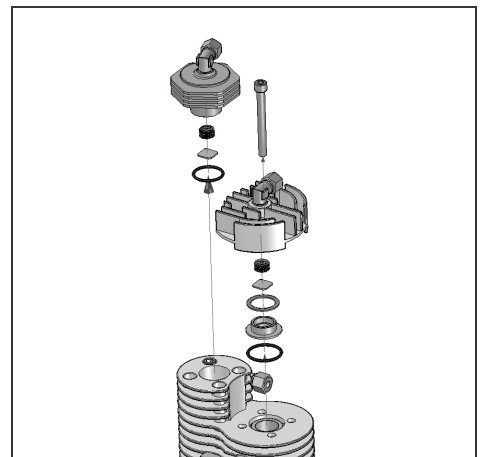

Observe the correct sequence when fitting together again.  
Check individual components for excessive wear. If the valve seat and valve disks are dented, replace the valves.  
Use only satisfactory gaskets and O-rings on reassembly.  
After finishing all maintenance work on the valves, turn the compressor manually and check whether all items have been correctly installed. After 30 minutes after starting, switch off the unit and check again.  
Replace the valves every 500 operating hours to avoid fatigue failure.

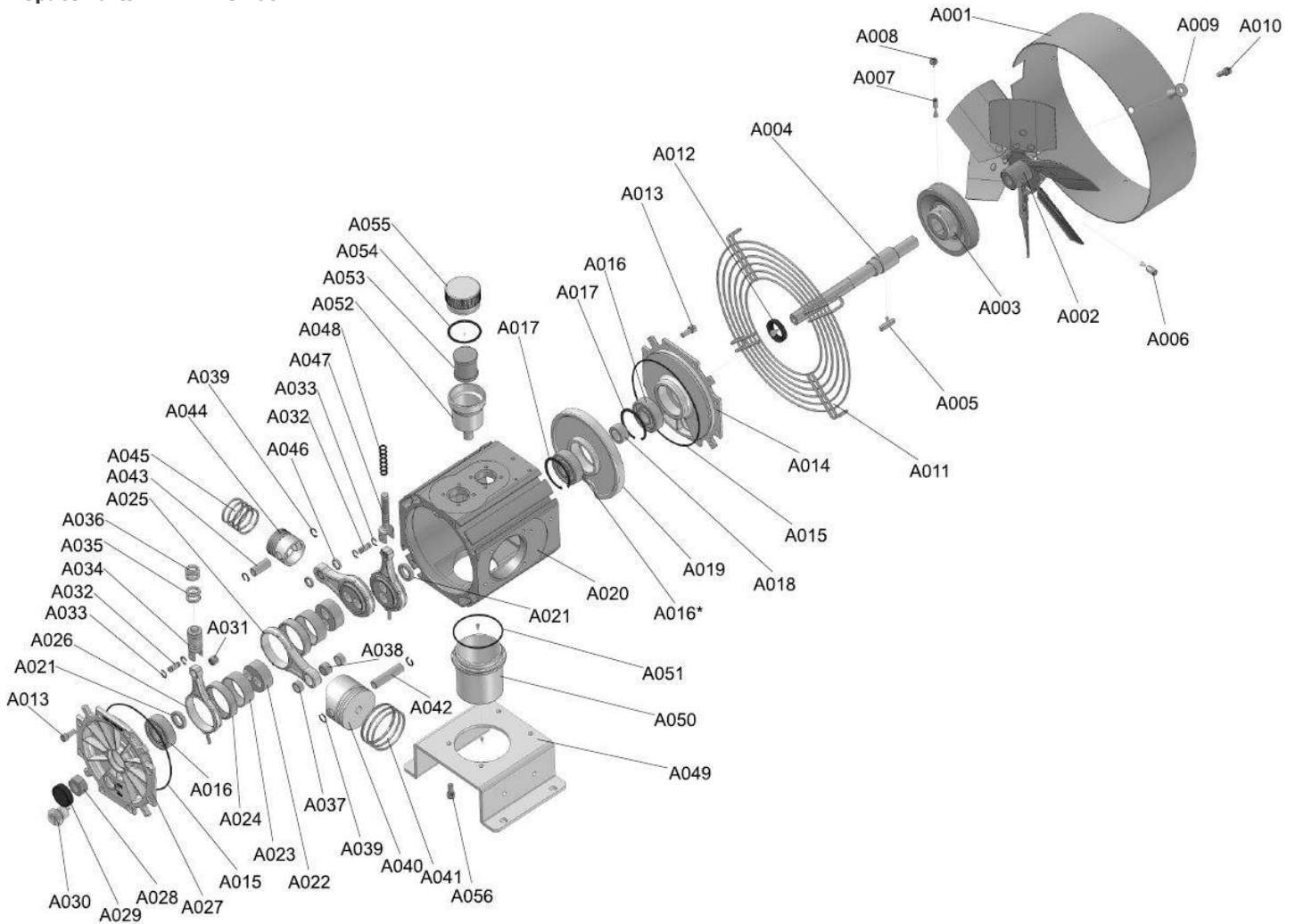

**Space Parts ATLANTIC 100:**

N° Parts	Description	Quantity	N° Parts	Description	Quantity	N°	Description	Quantity
A001	Metal Cover Fan	1	A020	Compressor crankcase	1	A039	Safety O-ring piston 1st - 2nd	4
A002	Fan	1	A021	Thickness	2	A040	Piston 1st stage	1
A003	Pulley	1	A022	Eccentric	4	A041	Piston rings 1st stage	1 Set.
A004	Compressor shaft	1	A023	Roller bearing	4	A042	Piston pin 1st stage	1
A005	Key	1	A024	Roller bearing	4	A043	Piston pin 2nd stage	1
A006	Screw	1	A025	Connecting rod 1st - 2nd Stage	2	A044	Piston 2nd stage	1
A007	Screw	1	A026	Connecting rod 3rd - 4th Stage	2	A045	Piston rings 2nd stage	1 Set.
A008	Nut	1	A027	Flange	1	A046	Trickiness connecting rod 2nd	2
A009	Washer	3	A028	Nut	1	A047	Piston 4th stage	1
A010	Screw	4	A029	Cover Oil seal	1	A048	Piston rings 4th stage	Set. 1
A011	Metal Wire	1	A030	Visual level plug oil	1	A049	Bracket Compressor	1
A012	Oil seal	1	A031	Roller bearing	2	A050	Oil cap	1
A013	Screw	16	A032	Piston pin 3rd - 4th stage	2	A051	O-ring	1
A014	Flange	1	A033	Safety O-ring piston 3rd - 4th	4	A052	Vat Oil Vapour	1
A015	O-ring	2	A034	Piston 3rd stage	1	A053	Filter Olio vapour	1
A016	Bearing	3	A035	Piston rings 3rd stage	1 Set.	A054	O-ring	1
A017	Circlip ring	2	A036	Piston rings 3rd stage	1 Set.	A055	Cork	1
A018	Thickness	1	A037	Trickiness connecting rod 1st stage	2	A056	Screw	6
A019	Flange	1	A038	Roller bearing 1st - 2nd stage	2			

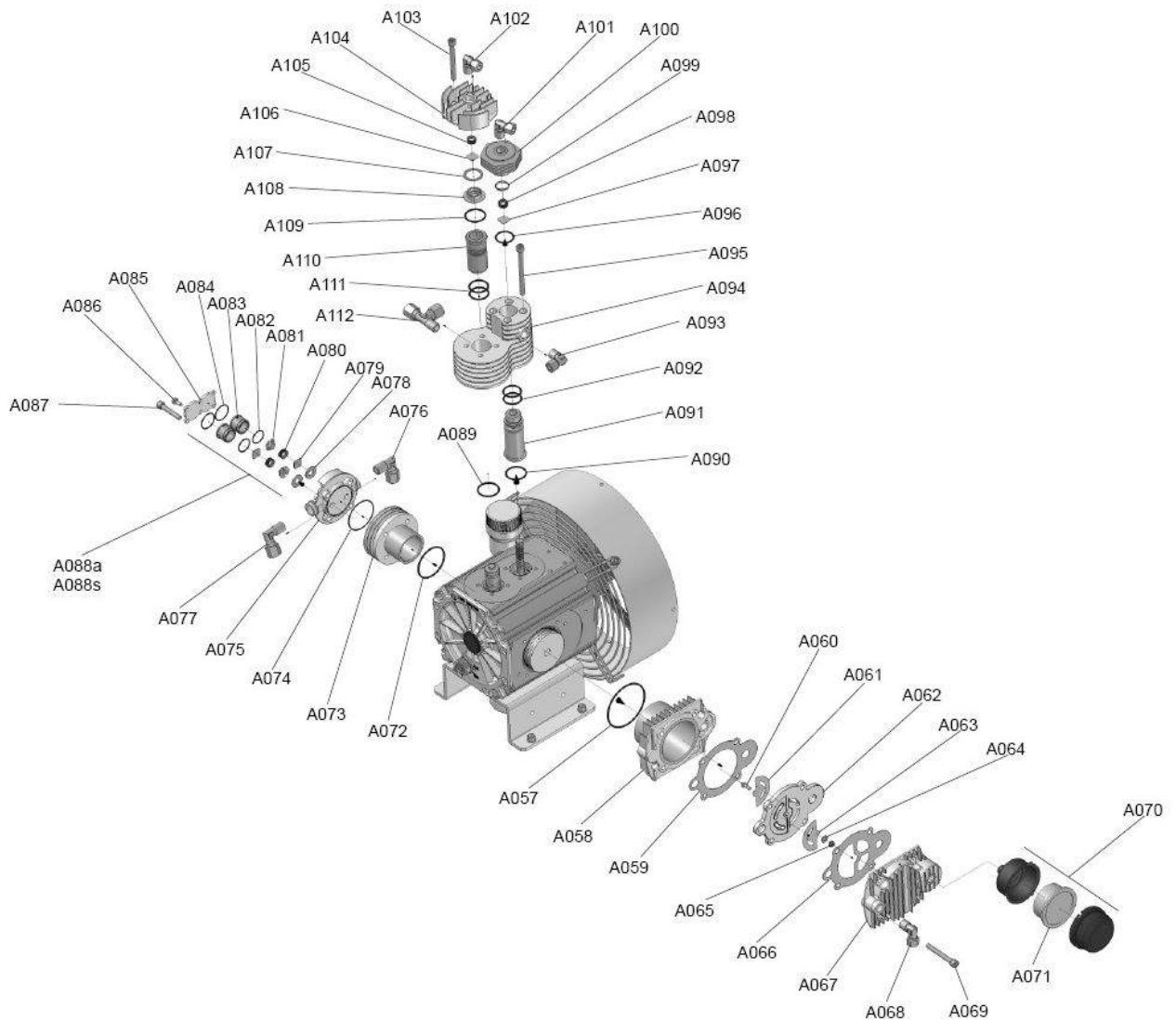
**Space parts ATLANTIC 100:**

N°	Descriptor	Quantity	N°	Description	Quantity	N°	Description	Quantity
A057	O-ring	1	A077	Connections L 1/4" tube 8mm	1	A095	Screw	1
A058	Cylinder 1st Stage	1	A078	Inferior body valve 2 <sup>nd</sup> stage	2	A096	O-ring	1
A059	Cylinder Gasket 1st Stage	1	A079	Valve plate 2 <sup>nd</sup> stage	2	A097	Plate valve 4 <sup>th</sup> stage	1
A060	Screw	1	A080	Spring valve 2 <sup>nd</sup> stage	2	A098	Spring valve 4 <sup>th</sup> stage	1
A061	Lamella	1	A081	Central body valve 2 <sup>nd</sup> stage	2	A099	Washer Valve Head	1
A062	Valve plate	1	A082	O-ring	2	A100	Head 4 <sup>th</sup> stage	1
A063	Lamella	1	A083	Body suction valve 2 <sup>nd</sup> stage	2	A101	Connection L 1/4"	1
A064	Washer	1	A084	O-ring	2	A102	Connection L 1/4"	1
A065	Dado	1	A085	Cover valves	1	A103	Screw	4
A066	Top Gasket 1 <sup>st</sup> stage	1	A086	Screw	6	A104	Head 3 <sup>rd</sup> stage	1
A067	Head 1 <sup>st</sup> stage	1	A087	Screw	4	A105	Spring 3 <sup>rd</sup> stage	1
A068	Connection L 1/4" tube 10mm	1	A088A	Intake valve	1	A106	Plate valve 3 <sup>rd</sup> stage	1
A069	Screw	4	A089	O-ring	1	A107	Seal washer Head 3 <sup>rd</sup> stage	1
A070	Complete suction Filter	1	A090	O-ring	1	A108	Inferior body valve 3 <sup>rd</sup> stage	1
A072	Suction filter cartridge	1	A091	Cylinder 4 <sup>th</sup> stage	1	A109	O-ring	1
A073	Cylinder 2 <sup>nd</sup> stage	1	A092	O-ring	2	A110	Cylinder 3 <sup>rd</sup> Stage	1
A074	O-ring	1	A093	Connections L 1/4" tube 8mm	1	A111	O-ring	2
A075	Head 2 <sup>nd</sup> stage	1	A094	Aluminium cylinder 3 <sup>rd</sup> - 4 <sup>th</sup> stage	1	A112	Connection a T 1/4"	1
A076	Connections T 1/4" tube 10mm	1						

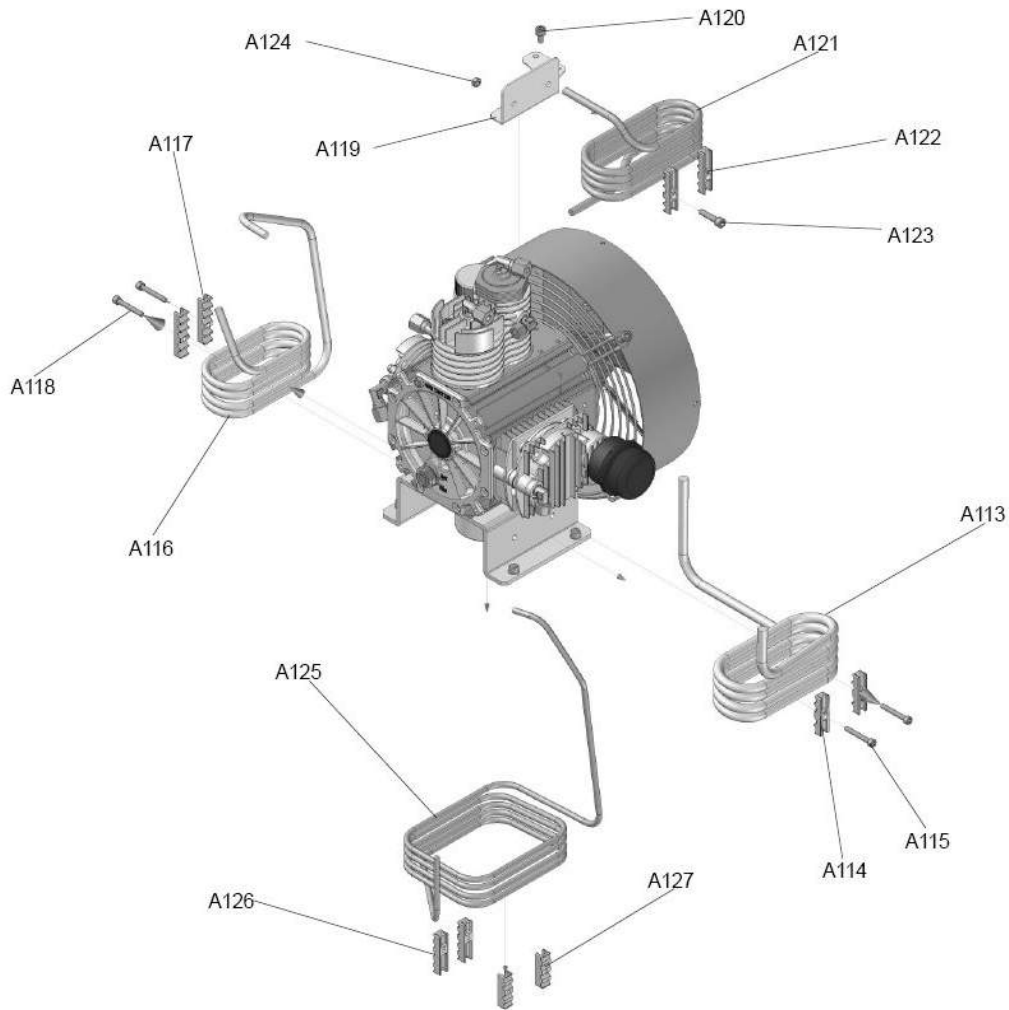
**Space parts ATLANTIC 100:**

N°	Description	Quantity	N°	Description	Quantity
<b>A113</b>	Intercooler 1 <sup>st</sup> - 2 <sup>nd</sup> Stage	1	<b>A121</b>	Intercooler 3 <sup>rd</sup> Stage - separator	1
<b>A114</b>	Fixing tube 1 <sup>st</sup> - 2 <sup>nd</sup> Stage	2	<b>A122</b>	Fixing tube 3 <sup>rd</sup> - separator	2
<b>A115</b>	Screw	2	<b>A123</b>	Screw	3
<b>A116</b>	Intercooler 2 <sup>nd</sup> - 3 <sup>rd</sup> Stage	1	<b>A124</b>	Nut	2
<b>A117</b>	Fixing tube 2 <sup>nd</sup> - 3 <sup>rd</sup> Stage	2	<b>A125</b>	Intercooler 4 <sup>th</sup> Stage - separator	1
<b>A118</b>	Screw	2	<b>A126</b>	Fixing tube 4 <sup>th</sup> Stage - separator	2
<b>A119</b>	Bracket tube 3 <sup>rd</sup> Stage	1	<b>A127</b>	Fixing tube 4 <sup>th</sup> Stage - separator	2
<b>A120</b>	Screw	3			

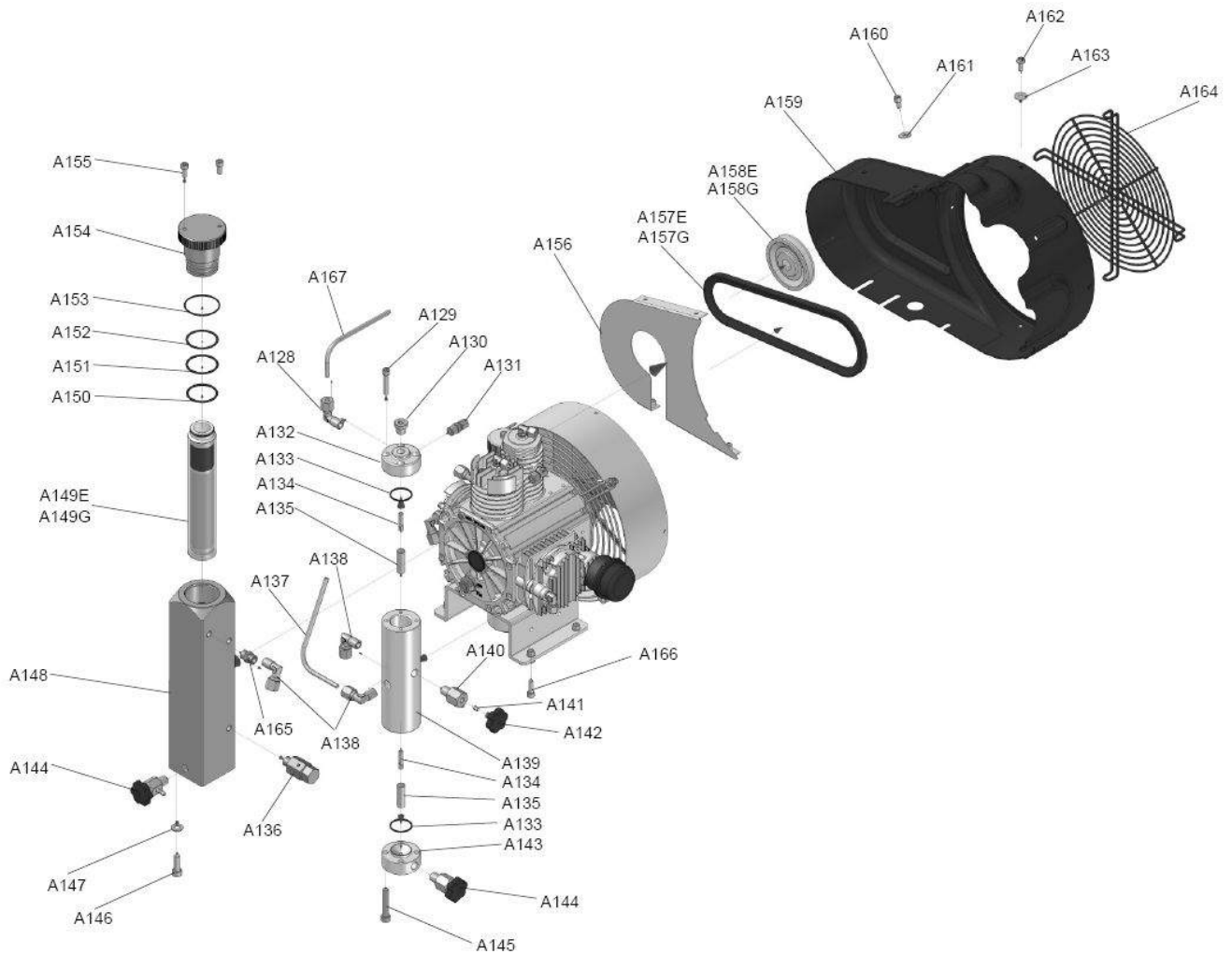
**Space parts ATLANTIC 100:**

N°	Description	Quantity	N°	Description	Quantity	N°	Description	Quantity
<b>A128</b>	Connection L 1/4" tube 8mm	1	<b>A143</b>	Plug filter separator Inferior	1	<b>A157E60HZ</b>	Belt for electric engine 60 Hz	1
<b>A129</b>	Screw	4	<b>A144</b>	Condensate drain valve complete	2	<b>A157G</b>	Belt for gasoline engine	1
<b>A130</b>	Plug 1/4"	6	<b>A145</b>	Screw	4	<b>A158E50HZ</b>	Pulley for electric engine 50Hz	1
<b>A131</b>	Connection 1/4 Tube 8mm	2	<b>A146</b>	Screw	4	<b>A158E60HZ</b>	Pulley for electric engine 60Hz	1
<b>A132</b>	Plug filter separator	1	<b>A147</b>	Washer	4	<b>A158G</b>	Pulley for gasoline engine	1
<b>A133</b>	O-ring	2	<b>A148</b>	Body carbons filter Atlantic	1	<b>A159P</b>	Cover belt electric compressor	1
<b>A134</b>	Element separator	2	<b>A149E</b>	Filter cartridge ATLANTIC electric	1	<b>A159G</b>	Cover belt gasoline compressor	1
<b>A135</b>	Element separator	2	<b>A149G</b>	Filter cartridge ATLANTIC gasoline	1	<b>A160</b>	Screw	2
<b>A136-225</b>	Safety valve 225 Bar	1	<b>A150</b>	O-ring	1	<b>A161</b>	Washer	6
<b>A136-330</b>	Safety valve 330 Bar	1	<b>A151</b>	O-ring	1	<b>A162</b>	Metal Wire Cover fan	1
<b>A137</b>	Tube separator – filter	1	<b>A152</b>	O-ring	1	<b>A163</b>	Washer	6
<b>A138</b>	Connection L 1/4" tube 6mm	3	<b>A153</b>	O-ring	1	<b>A164</b>	Screw	4
<b>A139</b>	Body filter separator	1	<b>A154</b>	Plug carbons filter Atlantic	1	<b>A165</b>	Connection 1/4" for hose	1
<b>A140</b>	Drain valve housing	1	<b>A155</b>	Screw	1	<b>A166</b>	Screw	1
<b>A141</b>	TEFLON nut	1	<b>A156</b>	Metallic Cover belt	1			
<b>A142</b>	Screw of discharge	1	<b>A157E50HZ</b>	Belt for electric engine 50 Hz	1			